

Code 700158

Code 600807

AXMINSTER

INDUSTRIAL SERIES



UNION-ONE

TSCE-12R 305mm Table Saw

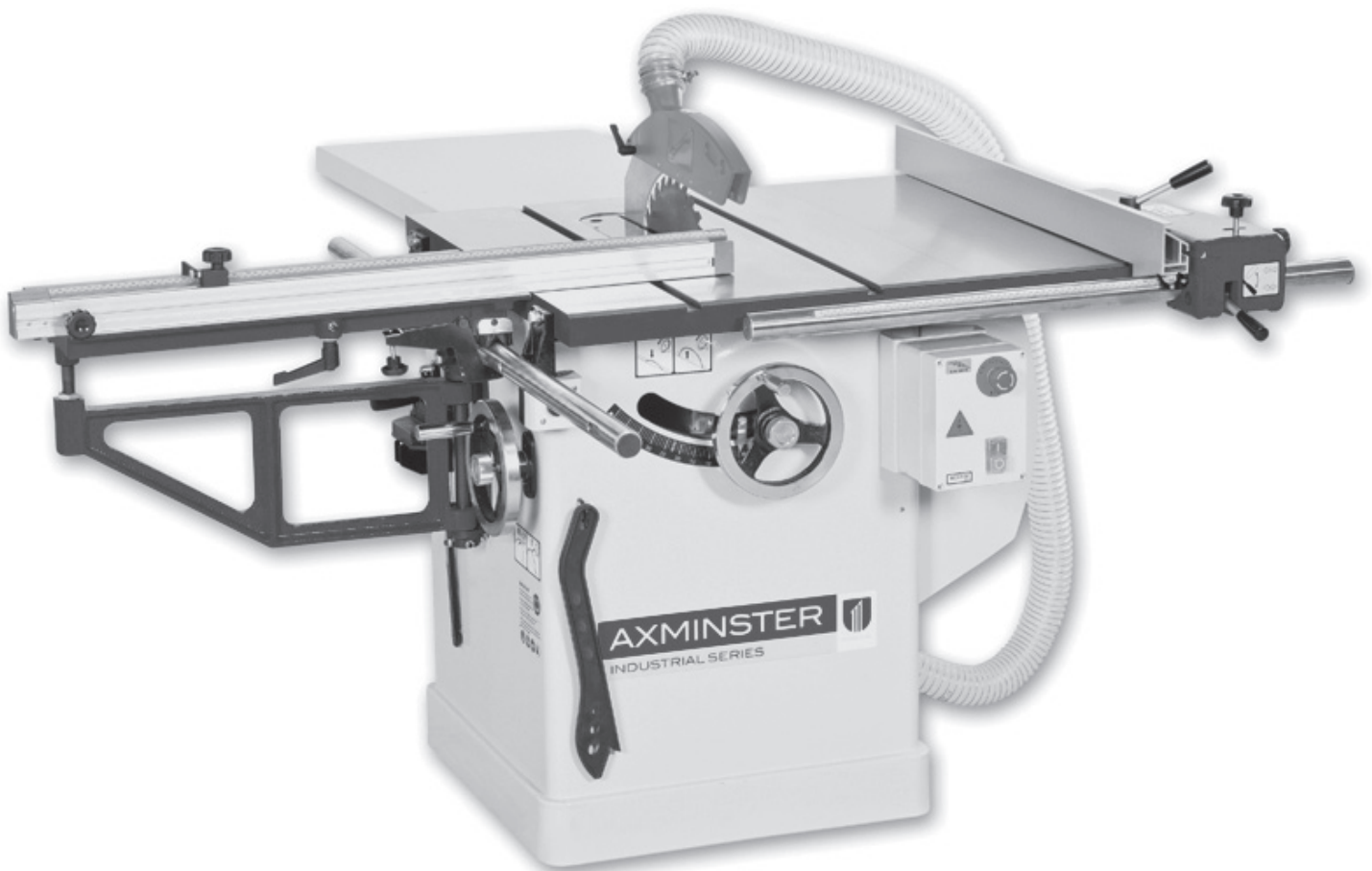

Table of Contents

Table of Contents	2
Warnings	3
Specifications	6
Shipping Contents	7
Unpacking	7
Cleaning	7
Contents of the Shipping Container	8
Assembly	9
Motor Cover	9
Handwheel Assembly	9
Miter Gauge and Fence Storage Hooks	9
Extension Wing	10
Blade Installation/Replacement	10
Riving Knife and Guard Installation	11
Mounting Rails & Extension Table	12
Switch Installation	12
Electrical Connections	12
Adjustments	13
Handwheel Adjustments	13
Insert Adjustment	13
Miter Gauge	13
Riving Knife Adjustment	14
Blade Alignment	15
Adjusting 45° and 90° Positive Stops	16
Changing the Belt	17
Maintenance	17
Cleaning	17
Lubrication	17
Miscellaneous	17
Troubleshooting	18
Table & Cabinet Assembly	19
Motor and Trunnion Assembly	22
Blade Guard Assembly	27
Wiring Diagrams	29

The specifications in this manual are given as general information and are not binding. Sellers have the right to effect at any time and without prior notice, changes or alterations to parts, fittings, and accessory equipment deemed necessary for any reason whatsoever.

Warnings

1. Read and understand the entire owner's manual before attempting assembly or operation.
2. Read and understand the warnings posted on the machine and in this manual. Failure to comply with all of these warnings may cause serious injury.
3. Replace the warning labels if they become obscured or removed.
4. This table saw is designed and intended for use by properly trained, experienced personnel and sales agent only. If you are not familiar with the proper and safe operation of a table saw, do not use until proper training and knowledge have been obtained.
5. Do not use this table saw for other than its intended use. If used for other purposes, Manufacturer disclaims any real or implied warranty and holds itself harmless from any injury that may result from that use.
6. Always wear approved safety glasses/face shields while using this table saw. Everyday eyeglasses only have impact resistant lenses; they are not safety glasses.
7. Before operating this table saw, remove tie, rings, watches and other jewelry, and roll sleeves up past the elbows. Remove all loose clothing and confine long hair. Non-slip footwear or anti-skid floor strips are recommended. Do **not** wear gloves.
8. Wear ear protectors (plugs or muffs) during extended periods of operation.
9. Some dust created by power sanding, sawing, grinding, drilling and other construction activities contain chemicals known to cause cancer, birth defects or other reproductive harm. Some examples of these chemicals are:
 - Lead from lead based paint.
 - Crystalline silica from bricks, cement and other masonry products.
 - Arsenic and chromium from chemically treated lumber.Your risk of exposure varies, depending on how often you do this type of work. To reduce your exposure to these chemicals, work in a well-ventilated area and work with approved safety equipment, such as face or dust masks that are specifically designed to filter out microscopic particles.
10. Do not operate this machine while tired or under the influence of drugs, alcohol or any medication.
11. Make certain the machine is properly grounded.
12. Make all machine adjustments or maintenance with the machine unplugged from the power source. A machine under repair should be RED TAGGED to show it must not be used until maintenance is complete.
13. Remove adjusting keys and wrenches. Form a habit of checking to see that keys and adjusting wrenches are removed from the machine before turning it on.
14. Keep safety guards in place at all times when the machine is in use. If removed for maintenance purposes, use extreme caution and replace the guards immediately.
15. Check the alignment of the riving knife, fence and miter slot to the blade. A caution decal is installed on each guard to remind the operator of the dangers of improper machine operation.
16. Check damaged parts. Before further use of the machine, a guard or other part that is damaged should be carefully checked to determine that it will operate properly and perform its intended function. Check for alignment of moving parts, binding of moving parts, breakage of parts, mounting and any other conditions that may affect its operation. A guard or other part that is damaged should be properly repaired or replaced.
17. Provide for adequate space surrounding work area and non-glare, overhead lighting.
18. Keep the floor around the machine clean and free of scrap material, oil and grease.

Warnings

19. Keep visitors a safe distance from the work area. Keep children away.
20. Make your workshop child proof with padlocks, master switches or by removing safety keys.
21. Give your work undivided attention. Looking around, carrying on a conversation and “horse-play” are careless acts that can result in serious injury.
22. Maintain a balanced stance at all times so that you do not fall or lean against the blade or other moving parts. Do not overreach or use excessive force to perform any machine operation.
23. Use the right tool at the correct speed and feed rate. Do not force a tool or attachment to do a job for which it was not designed. The right tool will do the job better and safer.
24. Use recommended accessories; improper accessories may be hazardous.
25. Maintain tools with care. Keep blade sharp and clean for the best and safest performance. Follow instructions for lubricating and changing accessories.
26. Check the saw blade for cracks or missing teeth. Do not use a cracked or dull blade or one with missing teeth or improper set. Make sure the blade is securely locked on the arbor.
27. Keep hands clear of the blade area. Do not reach past the blade to clear parts or scrap with the saw blade running. Never saw freehand. Avoid awkward operations and hand positions where a sudden slip could cause your hand to contact the blade.
28. Do not attempt to saw boards with loose knots or with nails or other foreign material, on its surface. Do not attempt to saw twisted, warped, bowed or “in wind” stock unless one edge has been jointed for guiding purposes prior to sawing.
29. Do not attempt to saw long or wide boards unsupported where spring or weight could cause the board to shift position.
30. Always use the riving knife, blade guard, push stick and other safety devices for all operations where they can be used. On operations such as dadoing or molding where the blade guard cannot be used, use feather boards, fixtures and other safety devices and use extreme caution. Reinstall the riving knife and blade guard immediately after completing the operation that required their removal.
31. Be sure the saw blade rotates clockwise when viewed from the motor side (Right side) of the machine.
32. Turn off the machine before cleaning. Use a brush or compressed air to remove chips or debris — do not use your hands.
33. Do not stand on the machine. Serious injury could occur if the machine tips over.
34. Never leave the machine running unattended. Turn the power off and do not leave the machine until it comes to a complete stop.
35. Remove loose items and unnecessary work pieces from the area before starting the machine.

Familiarize yourself with the following safety notices used in this manual:



This means that if precautions are not heeded, it may result in minor injury and/or possible machine damage.



This means that if precautions are not heeded, it may result in serious injury or possibly even death.

Shipping Contents

Unpacking

Remove box and wood crating completely from around saw. Check for shipping damage. Report any damage immediately to your distributor and shipping agent. Do not discard any shipping material until the Table Saw is assembled and running properly.

Compare the contents of your container with the parts lists in the next two pages to make sure all parts are intact. Missing parts, if any, should be reported to your distributor. Read the instruction manual thoroughly for assembly, maintenance and safety instructions.

1. Unbolt the saw from the skid.
2. Carefully slide the saw from the pallet onto the floor.

⚠WARNING Do not connect the tablesaw to the power source until all assembly has been completed! Failure to comply may cause serious injury!

The Table Saw should be placed in an area with a sturdy level floor, good ventilation and sufficient lighting. Leave enough space around the machine for mounting extension wings and rail assemblies, and loading and off-loading stock and general maintenance work.

Cleaning

Exposed metal surfaces, such as the table top and extension wings, have been given a protective coating at the factory. This should be removed with a soft cloth moistened with kerosene. Do not use acetone, gasoline, or lacquer thinner for this purpose. Do not use solvents on plastic parts, and do not use an abrasive pad because it may scratch the surfaces.

Specification

Model	TSCE-12R
Code	600087
Rating	Industrial
Power	3.75kW (415V)
Blade Dia/Bore	305mm/30mm
Blade Tilt	0° - 45°
Max Depth of Cut @ 45°	72mm
Max Depth of Cut @ 90°	102mm
Max Width of Cut with Fence	620mm
Table Size	836 x 787mm
Table Height	860mm
Sliding Table Size	354 x 650mm
Dust Extraction Outlet	100mm + 60mm
Min Extraction Airflow Required	1,000 m³/hr
Overall L x W x H	787 x 876 x 900mm (787 x 1,486 x 900mm with sliding table in use)
Weight	270kg

Specification

Model	TSCE-12R
Code	700158
Rating	Industrial
Power	2.2kW (230V)
Blade Dia/Bore	305mm/30mm
Blade Tilt	0° - 45°
Max Depth of Cut @ 45°	72mm
Max Depth of Cut @ 90°	102mm
Max Width of Cut with Fence	620mm
Table Size	836 x 787mm
Table Height	860mm
Sliding Table Size	354 x 650mm
Dust Extraction Outlet	100mm + 60mm
Min Extraction Airflow Required	1,000 m³/hr
Overall L x W x H	787 x 876 x 900mm (787 x 1,486 x 900mm with sliding table in use)
Weight	270kg

Contents of the Shipping Container

Main Saw Container

- 1 Table Saw (A)
- 1 Switch (B)
- 1 Table Insert (C)
- 1 Owner's Manual (D)
- 1 Inspection Record (not shown)

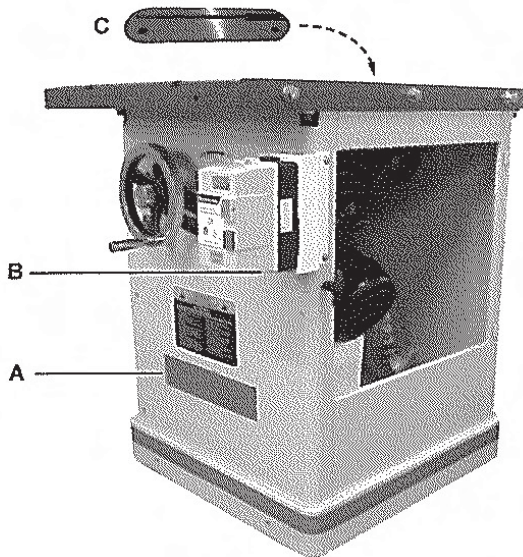

Main Saw Container

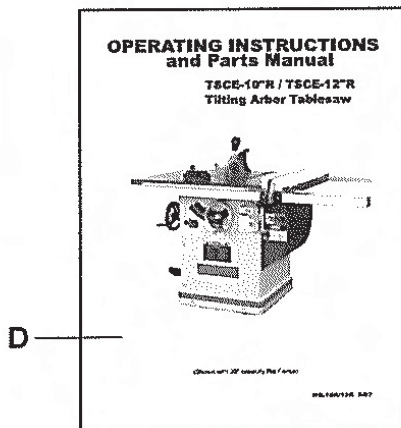

Extension Tables

Two extension tables are packaged in individual boxes.

(One extension table with sliding table)

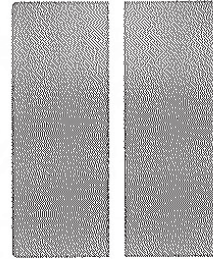

Extension Tables

Side Cover Box

- 1 Side Cover

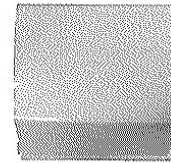

Contents of Side Cover Box

Small Box

The small box consists of the following items:

- 1 Blade Guard Assembly (D)
- 1 Riving Knife and Pawl Assembly (E)
- 1 Handwheel and Swivel Handle (F)
- 1 Lock Knob (G)
- 2 Large Hook for Us Rip Fence (H)
- 1 Small Hook for Miter Gauge (J)
- 1 Push Stick (K)
- 1 Miter Gauge Assembly (L)
- 1 Arbor Wrench (M)

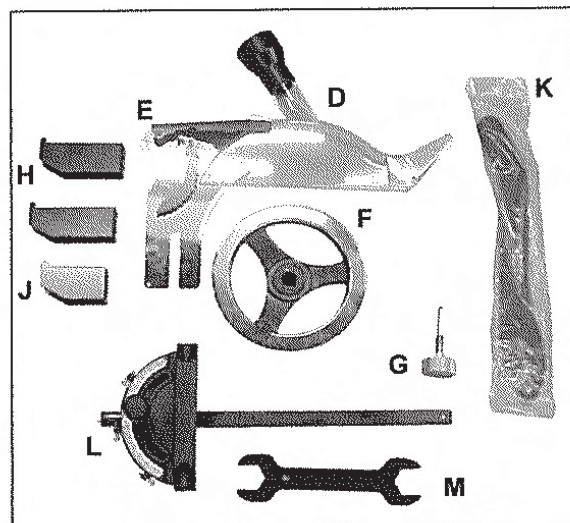

Contents of the Small Box

Assembly

Motor Cover

Referring to Figures 1 and 2:

Tools: 17mm Wrench

1. Remove *shipping bracket* (A) securing the *motor* (C) to table.
2. Remove the remaining *hex cap screw*, *lock washer*, and *flat washer* (Fig. 5) in the table edge.
3. Install *motor cover* (G) by aligning the *pins* (H) on the cover with *brackets* on the cabinet.
4. Fasten cover by pulling out the *latch* (J), closing the door, and releasing the latch.

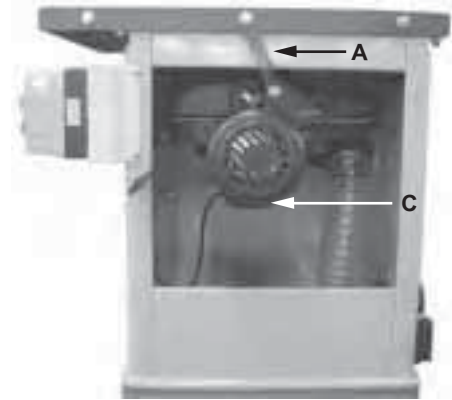

Figure 1

Handwheel Assembly

Referring to Figure 3:

Hardware: (2) Handle & Handwheel (C),
(2) Lock Knob (D), (2) Shaft Key (A)

Tools: 3mm hex wrench

The *front handwheel* (E) is installed at the factory. Install the *side handwheel* (C) as follows:

1. Line up the *key* (A) (taped to shaft) on the *shaft* (B) with the *key way* in the *handwheel* (C) and slide the handwheel onto the shaft.
2. Tighten the *set screw* on the handwheel hub (3mm hex wrench) securely to hold in place.
3. Install the center *lock knob* (D) by inserting into center hole in the shaft and threading in a clockwise direction.
4. Install the remaining *handwheel assembly* (E) in the same manner.



Figure 2

Miter Gauge and Fence Storage Hooks

Referring to Figure 3:

Hardware: (1) Small Hook (F), (2) Large Hook (K),
(6) 1/4" Flat Washers (J), (6) 1/4" Lock Washers (H),
(6) 1/4 x 5/8 Socket Head Cap Screws (G)

Tools: 5mm hex wrench

Mount the *small hook* (F) and two *large hooks* (K) to the side of the saw cabinet with six each 1/4 x 5/8 *socket head cap screws* (G), 1/4" *lock washers* (H) and 1/4" *flat washers* (J). Tighten with hex wrench.

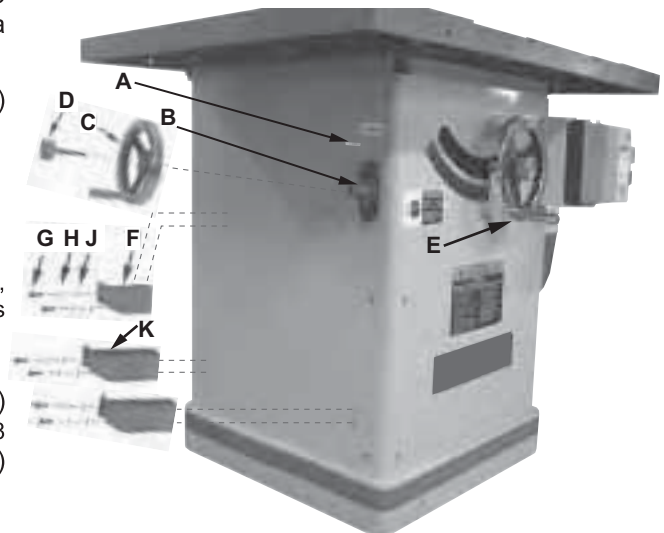

Figure 3

Extension Wing

Referring to Figures 4 and 5:

Hardware: (6) 7/16"x1-1/2" Hex Cap Bolts, (6) 7/16" Lock Washers, (6) 7/16" Flat Washers & (2) Extension Tables

Tools: 17mm Wrench, Straight Edge

1. Attach the left *extension wing* (A) to the *table* (B) with three each *hex cap screws* (E), *lock washers* (F) and *flat washers* (G). Snug so the extension wing can still be manually adjusted but do not tighten.
2. Adjust the extension wing horizontally so the front edge is flush with the front edge of the saw table (C). Then, using the straightedge as reference, adjust vertically so the tops of the extension wing and saw table are flush.
3. Tighten the three extension wing mounting screws.
4. Remove the mounting hardware (Fig. 5) from the table on the right side; then attach the right extension wing in the same manner.

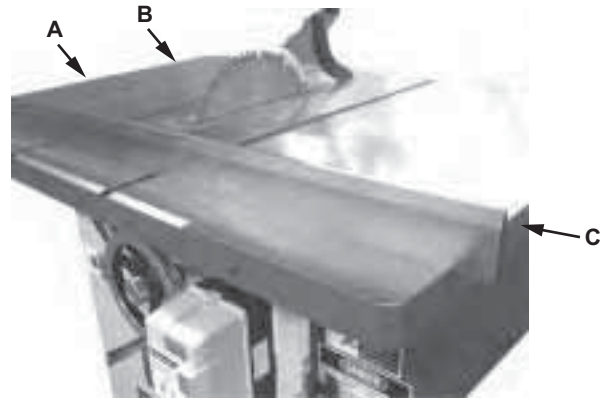

Figure 4

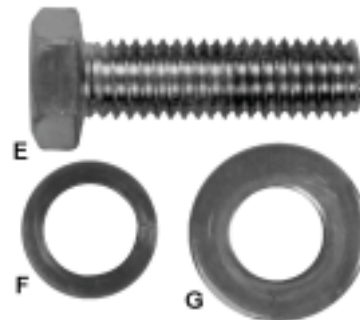

Figure 5

Blade Installation/Replacement

CAUTION Use care when working with or around sharp saw blade to prevent injury!

To install or replace a blade (refer to Figure 6):

Tools: 22mm Wrench (10") 38mm Wrench (Aus 12")
32mm Wrench (12")

1. Disconnect machine from power source.
2. Raise the *blade height* all the way up and set the *blade tilt* to 0° (refer to *Handwheel Adjustments* on page 13).
3. Remove the table insert.
4. Rotate the arbor to line up the *slot* (C) with the *arbor lock* (D).
5. Press the *arbor lock* (D) in the direction shown by the arrow to engage it into the *slot* (C) in the *arbor*. At the same time remove the *arbor nut* (A), loosening with a wrench if necessary.
6. Remove the *collar* (B).
7. Install the blade, making sure the cutting teeth at the top of the blade point toward the front of the saw. If unsure, refer to Figure 8 for the proper blade orientation.
8. Replace the *collar* (B) and *arbor nut* (A).
9. Engage the *arbor lock* (D) and tighten the *nut* (A) with a wrench.
10. Lower the blade below the table.

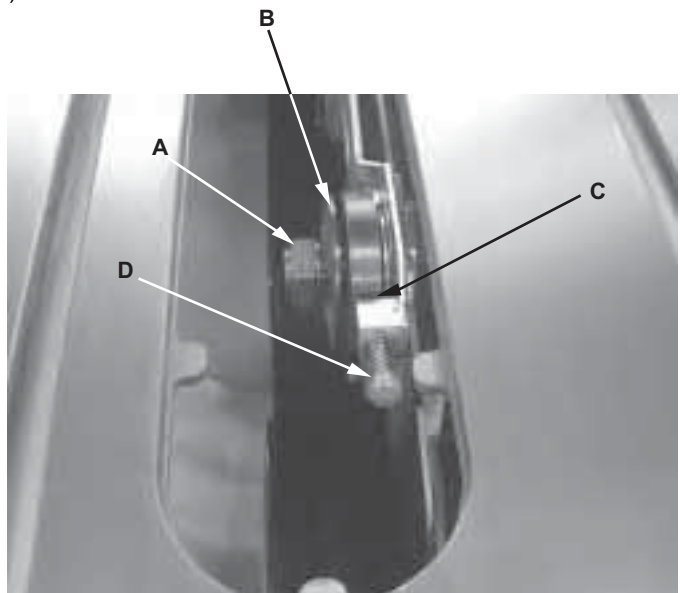

Figure 6

Riving Knife and Guard Installation

Description

Referring to Figure 7:

The complete *riving knife and guard assembly* is shown in A.

Installation

Referring to Figure 8:

1. Set the saw blade to the 90 degree position and raise it all the way (refer to *Handwheel Adjustments* on page 13).
2. Remove the table insert (J).
3. Located inside the table and accessible through the insert opening (Figure 8 inset), place the quick-release clamp lock handle (K) in the unlock position.
4. The floating clamp block (L) is spring loaded and will move away (O) from the fixed block (M), leaving a gap.
5. Insert the bottom of the riving knife (N1, N2) all the way into the gap between the *clamp blocks* (L, M); then lock the *handle* (K).
6. Replace the *insert* (J) back on the table. The saw blade and riving knife should protrude through the slot in the insert.

You should feel a snap as each piece locks in position. Attempt to lift as a test to make sure that they are securely locked in place.

Adjustment

The clamping blocks (L, M, Fig. 8) are adjusted at the factory and no further adjustment of the blade guard and riving knife assembly should be necessary. However, **proper alignment is very important**. Before operating the table saw, read *Riving Knife Adjustment* (p.14) to verify and follow the adjustment procedure if necessary.

Note: please use the correct thickness of *Riving Knife* to fit your blade.

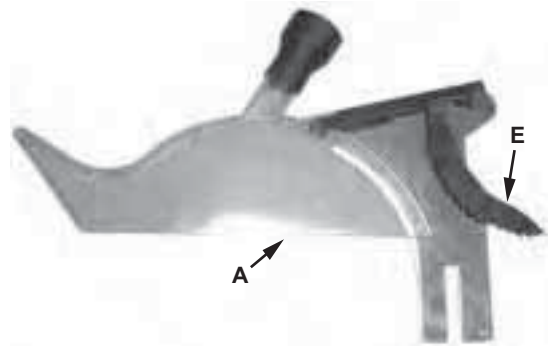

Figure 7

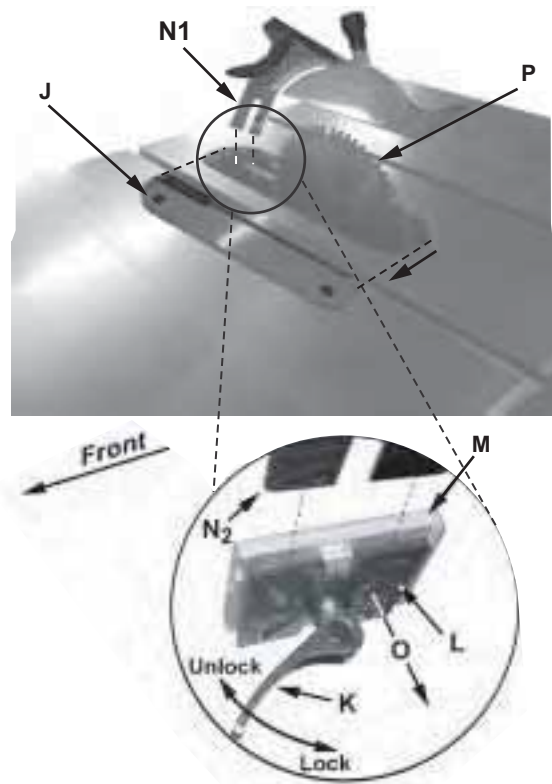

Figure 8

Mounting Rails & Extension Table

With the extension wings properly aligned, the rail and fence assembly can now be mounted to the saw. Refer to the *Rip Fence Owner's Manual* for mounting instructions for the rails, fence and optional wooden extension table.

Switch Installation

Referring to Figure 9:

Attaching the Switch Bracket Assembly

- *Tool:* 10mm Wrench

1. Loosen hex Nut and Lock Washer from the Switch Plate Carringe Bolt.
2. Place switch bracket assembly into cabinet front Left side.
3. Align the switch and tighten all hardware.

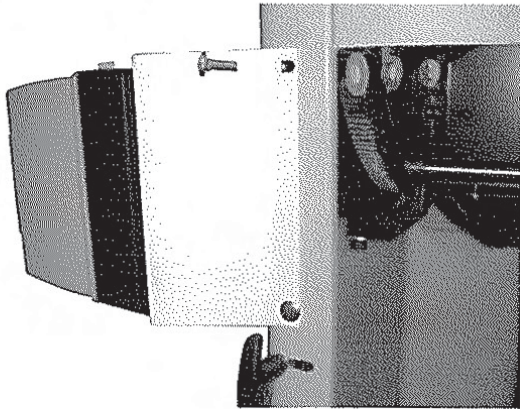

Figure 9

Electrical Connections

⚠WARNING A qualified electrician must complete all electrical connections! Failure to comply may result in serious injury!

⚠WARNING The machine must be properly grounded while in use to protect the operator from electric shock! Failure to comply may result in serious injury!

If a plug is provided with your machine, *do not* modify the plug. If it will not fit your electrical receptacle, have a qualified electrician install the proper connections to meet all electrical codes.

1. Disconnect the machine from the power source, (unplug).
2. Open the saw cabinet door.
3. Remove the cover from the motor junction box.
4. Change wires following the diagram on the inside of the cover.
5. Replace the cover and close the cabinet door.

Confirm power at the site is the same as the saw before making any electrical connections. Review the electrical schematics on page 29-30.

The on and off switch is **thermally protected**. If the saw motor is overloaded, or a momentary interruption of electrical current is sensed, the saw will shut off. Allow a few minutes for the saw to cool down and **reset by pushing the off button**.

Using extension cords can cause a loss in power to your machine. It is best if the saw is plugged directly into an outlet on a dedicated circuit.

Adjustments

Handwheel Adjustments

Referring to Figure 10:

The *front handwheel* (B) controls the raising and lowering of the blade (blade height).

The *side handwheel* (D) controls the blade tilt. The blade can be adjusted for a tilt between 90° (vertical or a setting of 0° on the scale) and 45° left tilt (D).

Blade height

1. Loosen the *lock knob* (A) on the *front handwheel* (B).
2. Turn the *handwheel* (B) clockwise to raise and counterclockwise to lower the blade.
3. Tighten the *lock knob* (A).

Blade tilt adjustment

1. Loosen the *lock knob* (C) on the side handwheel (D).
2. Turn the *handwheel* (D) counterclockwise to adjust the saw blade down to 45° right tilt. Turn clockwise to adjust the saw blade to maximum of 90°.
3. After selecting the position, tighten the *lock knob* (C).

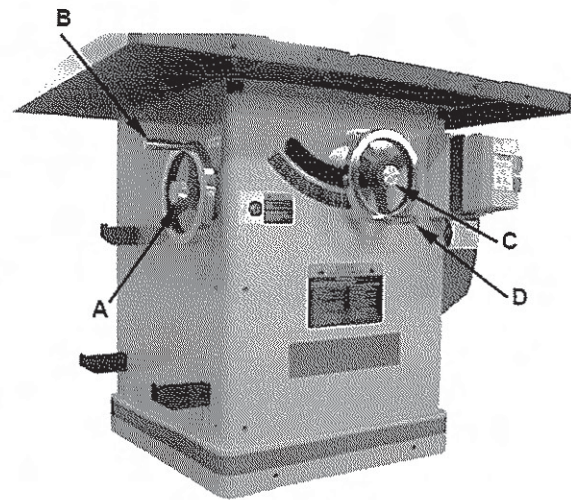

Figure 10

Insert Adjustment

Adjust the setscrews in the insert with a 3mm hex wrench (Figure 11) to ensure that the insert is stable and flush with the table top.

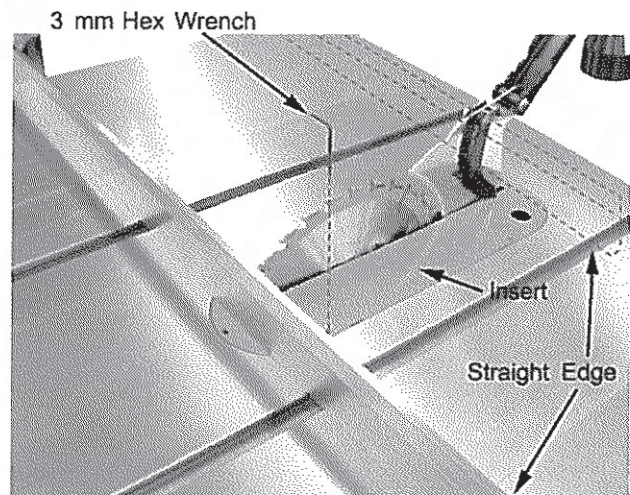

Figure 11

Miter Gauge

Referring to Figure 12:

1. Operate miter gauge by loosening the *lock knob* (A) and turning the *miter body* (B) to the desired angle. To move gauge beyond index stops of 45° and 90°, flip down the *stop* (C).
2. Adjust index stops by turning one of three adjustment screws (D).

Note: Always make test cuts. Do not rely solely on miter gauge indicator marks. There are holes in the miter gauge body that will allow you to mount a wooden extension fence.

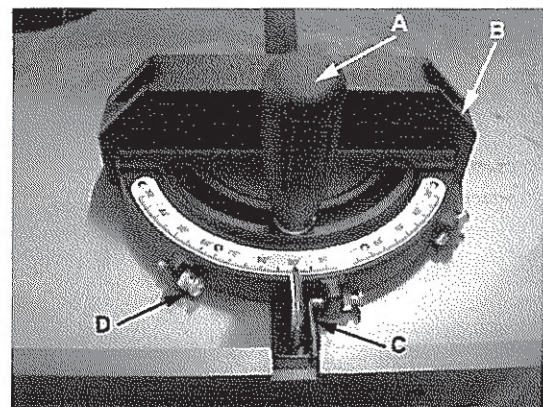

Figure 12

Riving Knife Adjustment

Lateral alignment

The saw blade and riving knife must be in line as close as possible with each other (*lateral alignment*) for the prevention of kickback. Upon initial blade guard and riving knife installation no further adjustment should be necessary. Alignment should be checked and adjusted, if required, after each blade change.

Check the alignment as follows:

1. Remove the *blade guard* and *pawl* (A, E, Fig. 7).
2. Place a *straightedge* (A, Fig. 13) on the table so it rests against the *blade* (B, Fig. 13) and *riving knife* (C, Fig. 13). Rotate the blade so the top of the blade tooth touches the straightedge.

The saw blade and riving knife must be in line.

If adjustment is required:

3. Remove the table insert.
4. Loosen the *lock handle* (A, Fig. 14) and remove the riving knife, making a note as to which direction the riving knife needs to be moved to align it with the saw blade.
5. Using a 3mm hex wrench, make adjustments to four *set screws* (D, Fig. 15) accessible through openings located in the corners of the *floating clamp block* (B, Fig. 15).
6. If necessary, repeat the above procedure.

Blade proximity alignment

The gap between the saw blade and riving knife must be between 3 and 8mm (Figure 16) to reduce the possibility of kickback. If adjustment is needed, note whether the blade to knife gap needs to be increased or decreased. Then adjust as follows:

1. Remove the blade guard, pawl, table insert and riving knife.

Referring to Figure 15:

2. With a 4mm hex wrench, loosen two *socket head flat screws* (E).

Note: These screws are accessible through openings on the *floating clamp block* (B) located diagonally on either side of the *lock handle* (A). They secure the *fixed clamp block* (C) to the riving knife *extension plate* (F).

Loosening these screws (E) will allow the *fixed clamp block* (C) to slide back and forth on the *extension plate* (F).

3. Slide the *fixed clamp block* (F) toward or away from the saw blade as required.

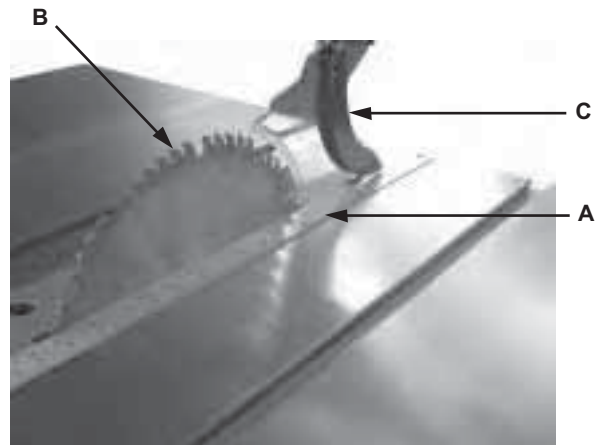

Figure 13

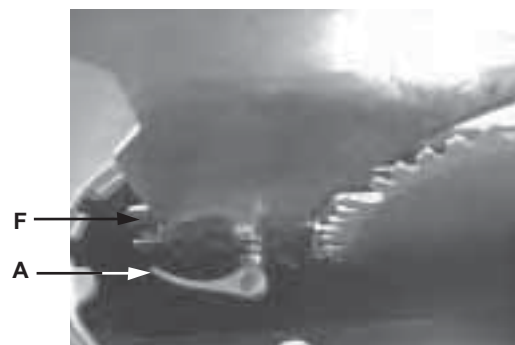

Figure 14

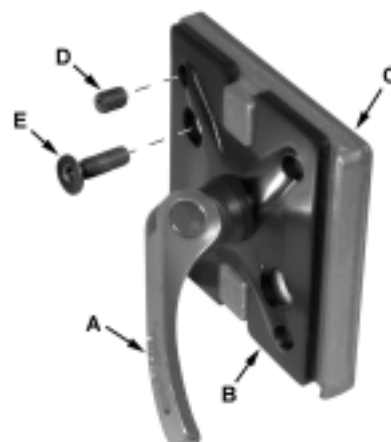

Figure 15

Spacing specification between
saw blade and riving knife:
minimum gap = 3mm
maximum gap = 8mm



Figure 16

4. Tighten the *socket head flat screws* (E).
5. Reinsert the riving knife; tighten the *lock handle* (A, Fig. 14) and check that the saw blade/knife gap is between 3 - 8mm (Figure 16).

Note: Attempt to make the gaps as even as possible.

Blade Alignment

Tools: 8mm hex wrench, combination square, marker

Blade alignment with the table is adjusted at the factory. After a period of use, or, after moving the saw to another location, the blade may no longer be aligned with the table.

To check and align the blade (refer to Figure 17):

1. Disconnect the saw from the power source.
2. Raise the blade guard up a way from the blade.
3. Choose a tooth on the far side of the blade (towards the rear) and position the tooth slightly above the table insert. Mark the tooth with a marker. Measure the distance from the side of the blade to the right T-slot edge using a combination square. Make sure to measure between the teeth not on the tooth (Figure 17).
4. Rotate the blade toward the front so that the marked tooth is just above the insert. Measure the distance from the side of the blade to the right T-slot edge. The two measurements should be the same.
5. If they are not the same, loosen four *hex socket cap screws* (A, Fig. 18) that hold the table to the base. Two are shown in Figure 18.
6. Make the needed adjustments and tighten the four hex socket cap screws firmly.
7. Check the alignment once again after tightening hardware.

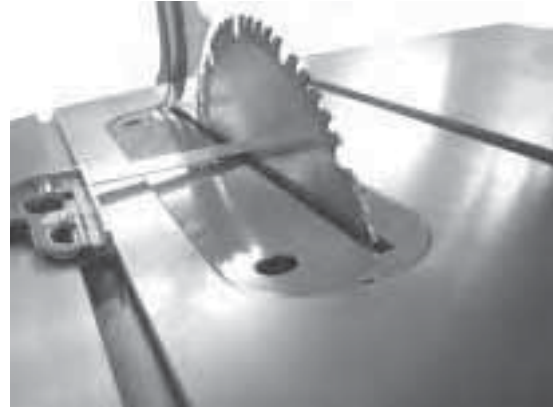

Figure 17

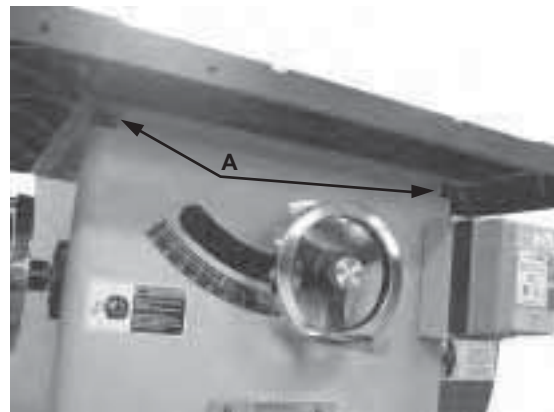

Figure 18

Adjusting 45° and 90° Positive Stops

The stops have been adjusted at the factory. After a period of use, or, after moving the saw to another location, the stops may no longer be set properly. To check and adjust the stops:

Tools: 12mm wrench, combination square

1. Disconnect saw from power source.
2. Raise the saw blade to its maximum height using the handwheel.
3. Set the blade at 90 degrees to the table by turning the blade tilting handwheel clockwise as far as it will go.
4. Place a combination square on the table against the blade and check to see that the blade is at a 90° angle to the table, Figure 19. Make sure square is not touching a blade tooth.
5. If blade is not at 90 degrees, open the motor cover door, loosen lock nut (A, Fig. 20) and turn adjusting stop screw (B, Fig. 20) on the front trunnion in, or out. The adjusting stop screw should stop against the front trunnion bracket when the blade is 90° to the table.
6. Tighten the lock nut (A, Fig. 20).
7. Set the blade at 45 degrees to the table by turning the blade tilting handwheel counter-clockwise as far as it will go. Place a combination square on the table against the blade. Make sure square is not touching a blade tooth.
8. If the blade is not 45 degrees, remove the raising and lowering handle. Loosen lock nut (A, Fig. 21) and turn adjusting stop screw (B, Fig. 21) on the front trunnion in, or out. The adjusting stop screw should stop against the front trunnion bracket when the blade is 45° to the table.
9. Check the accuracy of the pointer (C, Fig. 21) on the angle scale and adjust, if necessary.

Assembly and adjustment of the saw are now complete. Make sure all fasteners are tight. The saw may now be placed into operation.



Figure 19

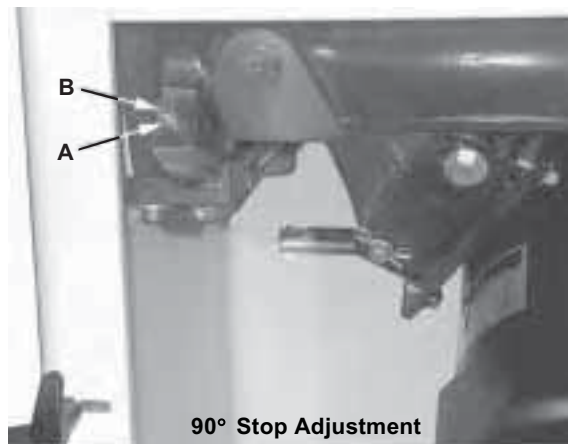

90° Stop Adjustment

Figure 20

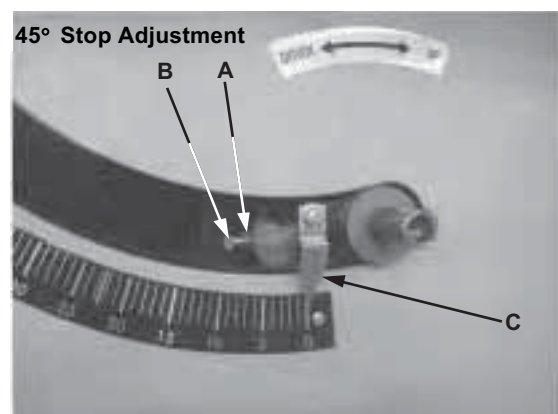

Figure 21

Changing the Belt

⚠WARNING Make all machine adjustments or maintenance with the machine unplugged from the power source. Failure to comply may cause serious injury!

Referring to Figure 22:

- **Tools:** 17mm Wrench
1. Disconnect the machine from the power source, unplug.
 2. Lower the blade to its lowest point.
 3. Loosen *two hex cap bolts (A)*.
 4. Take the tension off of the *belt (B)* by lifting up on the motor.
 5. Remove the belt from the arbor and motor pulleys.
 6. Replace and tension the belt. The weight of the motor should apply enough tension to the belt. Tighten the *hex cap bolts (A)*.
 7. Check the belt tension after the saw has been used for a few hours. Adjust as necessary.

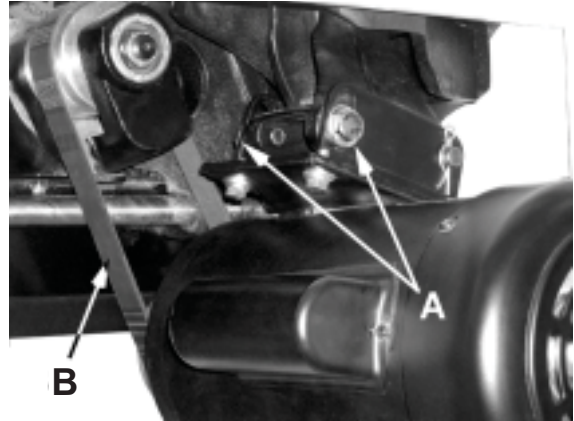

Figure 22

Maintenance

⚠WARNING Always disconnect power to the machine before performing maintenance. Failure to do this may result in serious personal injury.

Cleaning

Note: The following maintenance schedule assumes the saw is being used every day.

Daily:

Wipe down the table surface and grooves with a rust preventive.

Clean pitch and resin from the saw blade.

Weekly:

Table surface must be kept clean and free of rust for best results. Apply a coat of paste wax to the surface to facilitate this. An alternative is to apply white talcum powder, rubbed in vigorously once a week with a blackboard eraser; this will fill casting pores and form a moisture barrier. This method provides a table top that is slick and allows rust rings to be easily wiped from the surface. Important also is the fact that talcum powder will not stain wood or mar finishes as wax pickup does.

Clean motor housing with compressed air.

Wipe down the fence rails with a dry silicon lubricant.

Periodic:

Keep the inside of the cabinet and trunnion area clean.

Check for excessive play in the tilting and raising mechanism and in the saw arbor and re-adjust as required.

Check for belt tension and wear. Readjust or replace belt as required.

Lubrication

Grease the tilting worm gear, raising worm gear, castor system worm gear and the trunnion areas with a good grade non-hardening grease.

Check all adjustments after lubricating.

Miscellaneous

Routinely check condition of the following items:

Mounting bolts

Power switch

Saw blade

Blade guard assembly

Troubleshooting

Trouble	Possible Cause	Solution
Saw stops or will not start	Overload tripped Saw unplugged from wall or motor Fuse blown or circuit breaker tripped Cord damaged	Allow motor to cool and reset by pushing off switch Check all plug connections Replace fuse or reset circuit breaker Replace cord
Does not make accurate 45° or 90° cuts	Stops not adjusted correctly Angle pointer not set accurately Miter gauge out of adjustment	Check blade with square and adjust stops Check blade with square and adjust pointer Adjust miter gauge
Material binds blade when ripping	Fence not aligned with blade Warped wood Excessive feed rate Splitter not aligned with blade	Check and adjust fence Select another piece of wood Reduce feed rate Align splitter with blade
Saw makes unsatisfactory cuts	Dull blade Blade mounted backwards Gum or pitch on blade Incorrect blade for cut Gum or pitch on table	Sharpen or replace blade Turn blade around Remove blade and clean Change blade to correct type Clean table
Blade does not come up to speed	Extension cord too light or too long Low shop voltage Motor not wired for correct voltage	Replace with adequate size cord Contact your local electric company Refer to motor junction box
Saw vibrates excessively	Stand on uneven floor Damaged saw blade Bad poly v-belts Bent pulley Improper motor mounting Loose hardware	Reposition on flat, level surface Replace saw blade Replace poly v-belts Replace pulley Check and adjust motor Tighten hardware
Rip fence binds on guide rails	Guide rails or extension wing not installed correctly Guide of rip fence not adjusted properly	Reassemble guide rails, refer to fence manual Adjust guides, refer to fence manual
Material kicked back from blade	Rip fence out of alignment Splitter not aligned with blade Feeding stock without rip fence Splitter not in place Dull blade Letting go of material before it is past blade Anti-kick back plates dull	Align rip fence with miter slot Align splitter with blade Install and use rip fence Install and use splitter (with guard) Replace blade Push material all the way past blade before releasing work Replace or sharpen anti-kick back plates
Blade does not raise or tilt freely	Sawdust and debris in raising and tilting mechanisms	Clean and regrease

Table and Cabinet Assembly (Right tilt)

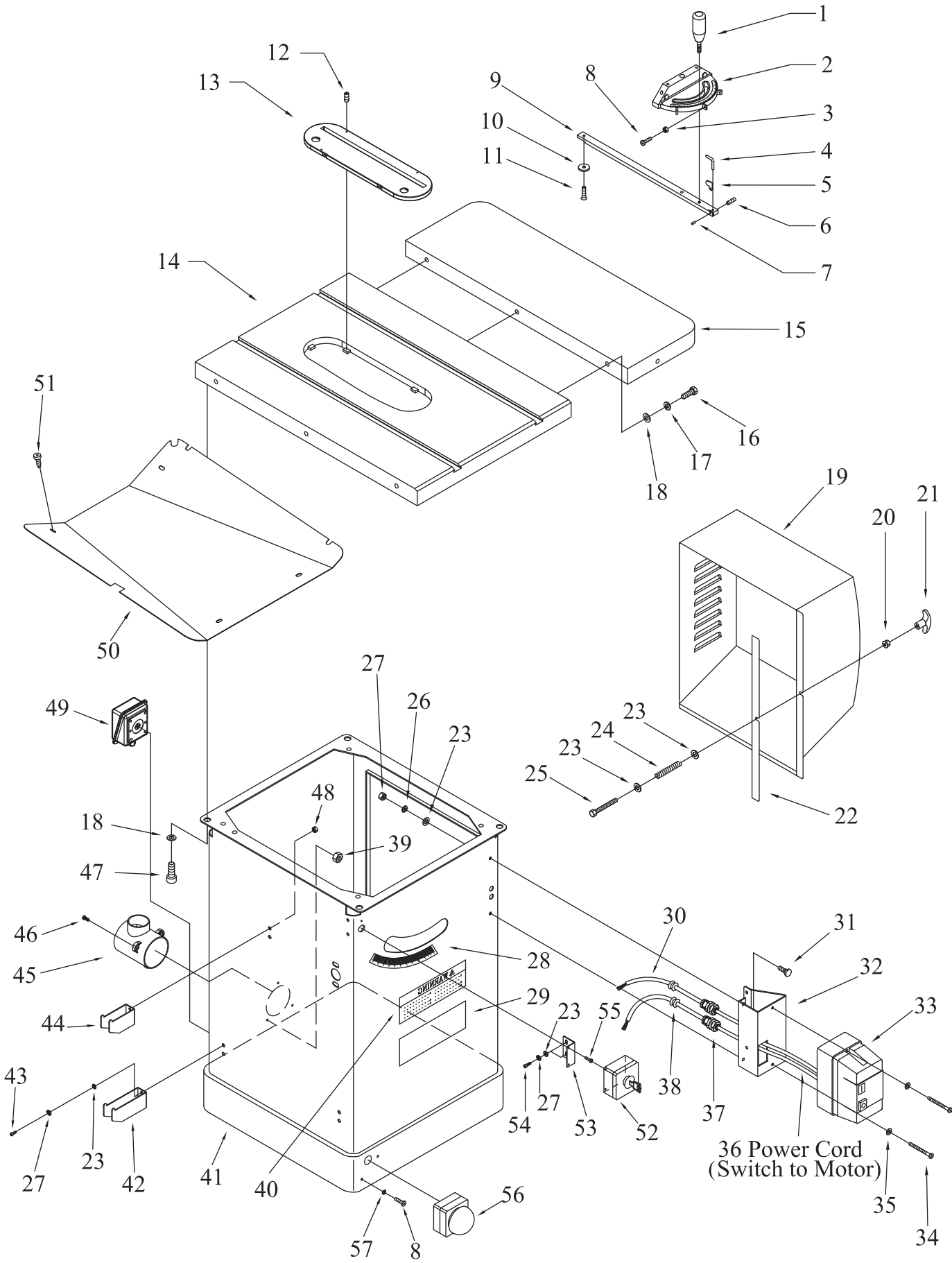

Table and Cabinet Assembly(Right tilt)

Index No.	Part No.	Description	Size	Qty.
1.....	UOTS10-1.....	Lock Knob.....		1
2.....	UOTS10-2.....	Miter Gauge Body.....		1
3.....	UOTS10-3.....	Hex Nut.....	M5.....	3
4.....	UOTS10-4.....	Pointer.....		1
5.....	UOTS10-5.....	Stop Link.....		1
6.....	UOTS10-6.....	Set Screw.....	M5x5.....	1
7.....	UOTS10-7.....	Special Pin.....	M3x6.....	1
8.....	UOTS10-8.....	Screw.....	M5x20.....	5
9.....	UOTS10-9.....	Guide Bar.....		1
10.....	UOTS10-10.....	Guide Washer.....		1
11.....	UOTS10-11.....	Flat Head Screw.....	M6x8.....	1
12.....	UOTS10-12.....	Set Screw.....	1/4"x3/8".....	6
13.....	TSCE10-13.....	Table Insert.....		1
.....	TSCE12-13.....	Table Insert.....		1
13A.....	TSCE10-13A.....	Dado Insert (optional).....		1
.....	TSCE12-13A.....	Dado Insert (optional).....		1
14.....	TSCE10-14.....	Table.....		1
.....	TSCE12-14.....	Table.....		1
15.....	UOTS12-15.....	Extension Wing.....		2
.....	TSCE12-15.....	Extension Wing.....		2
16.....	UOTS10-16.....	Hex Cap Screw.....	7/16"x1-1/2".....	6
17.....	UOTS10-17.....	Lock Washer.....	7/16".....	6
18.....	UOTS10-18.....	Flat Washer.....	7/16".....	6
19.....	TSCE10-19.....	Motor Cover.....		1
.....	TSCE12-19.....	Motor Cover.....		1
20.....	UOTS10-20.....	Flange Nut.....	M6.....	1
21.....	UOTS10-21.....	Handle.....		1
22.....	UOTS10-22.....	Foam Strip.....		1
23.....	UOTS10-23.....	Flat Washer.....	1/4".....	14
24.....	UOTS10-24.....	Spring.....		1
25.....	UOTS10-25.....	Hex Cap Bolt.....	M6x50.....	1
26.....	UOTS10-26.....	Lock Washer.....	1/4".....	10
27.....	UOTS10-27.....	Hex Nut.....	1/4".....	6

Table and Cabinet Assembly(Right tilt)

Index No.	Part No.	Description	Size	Qty.
28.....	UOTS10-28.....	Tilt Scale.....		1
29.....	UOTS10-29.....	Logo Lable.....		1
30.....	TSCE10-30.....	Power Cord.....		1
.....	TSCE12-30.....	Power Cord.....		1
31.....	UOTS10-31.....	Carriage Bolt.....	1/4"×3/4".....	4
32.....	TSCE10-32.....	Switch Base.....		1
33.....	UOTS10-33.....	Magnetic Switch.....	3hp.1ph.230v.....	1
.....	UOTS10-33A.....	Magnetic Switch.....	5hp.3ph.230v.....	1
.....	UOTS10-33B.....	Magnetic Switch.....	5hp.3ph.460v.....	1
.....	UOTS10-33C.....	Magnetic Switch.....	5hp.1ph.230v.....	1
34.....	UOTS10-34.....	Screw.....	3/16"×3/4".....	2
35.....	UOTS10-35.....	Flat Washer.....	3/16".....	2
36.....	UOTS10-36.....	Power Cord.....		1
.....	UOTS12-36.....	Power Cord.....		1
37.....	UOTS10-37.....	Cable Gland.....		3
38.....	UOTS10-38.....	Snap Bushing.....	1/2".....	2
39.....	TSCE10-39.....	Nylon Nut.....	1/4".....	3
40.....	UOTS10-40.....	Warning Label.....		1
41.....	TSCE10-41.....	Cabinet.....		1
.....	TSCE12-41.....	Cabinet.....		1
42.....	TSCE10-42.....	Fence Hook.....		2
43.....	TSCE10-43.....	Round Head Screw.....	M6×12.....	6
44.....	TSCE10-44.....	Miter Gauge Hook.....		1
45.....	TSCE10-45.....	Dust Hose Adapter.....		1
46.....	TSCE10-46.....	Hex Head Screw.....	1/4"×5/8".....	3
47.....	UOTS10-47.....	Hex Socket Head Screw.....	7/16"×3/4".....	4
48.....	TSCE10-48.....	Special Nut.....	1/4".....	6
49.....	TSCE10-49.....	Cord Connector Box.....		1
50.....	TSCE10-50.....	Lower Panel.....		1
.....	TSCE12-50.....	Lower Panel.....		1
51.....	UOTS10-51.....	Tap Screw.....	M5×10.....	4
52.....	S1220024.....	Stop Switch (For Normal Stop).....		1
53.....	12200115.....	Switch Base.....		1

Table and Cabinet Assembly(Right tilt)

Index No.	Part No.	Description	Size	Qty.
54.....	901M06016.....	Hex Socket Head Screw.....	M6x16.....2
55.....	906316012.....	Screw.....	3/16x1/2.....2
56.....	S12200015.....	Foot Stop Switch.....1
57.....	914M051001.....	Flat Washer.....	M5.....2

Motor and Trunnion Assembly

Index No.	Part No.	Description	Size	Qty.
101.....	UOTS10-101.....	Arbor Nut.....1
.....	UOTS12-101.....	Arbor Nut.....1
102.....	UOTS10-102.....	Arbor Flange.....1
.....	TSCE12-102.....	Arbor Flange.....1
103.....	UOTS10-103.....	Saw Blade(Optional).....	10"(254mm)1
.....	UOTS12-103.....	Saw Blade(Optional).....	12"(305mm)1
104.....	TSCE10-104.....	Arbor With Flange.....1
.....	TSCE12-104.....	Arbor With Flange.....1
105.....	UOTS10-105.....	Key.....	M5x44.....1
.....	UOTS12-105.....	Key.....	1/4"x1-3/4"...1
106.....	UOTS10-106.....	Ball Bearing.....	6203zz.....2
.....	UOTS12-106.....	Ball Bearing.....	6005zz.....2
107.....	UOTS10-107.....	Bearing Load Spring.....4
.....	UOTS12-107.....	Bearing Load Spring.....4
108.....	TSCE10-108.....	Bearing Load Spacer.....1
.....	TSCE12-108.....	Bearing Load Spacer.....1
109.....	UOTS10-109.....	Set Screw.....	1/4"x3/8".....6
110.....	TSCE10-110.....	Arbor Pulley.....1
.....	TSCE12-110.....	Arbor Pulley.....1
111.....	UOTS10-111.....	Collar.....1
.....	UOTS12-111.....	Collar.....1
112.....	UOTS10-112.....	Key.....	1/4"x1/4"x451
113.....	UOTS10-113.....	Lock Washer.....	3/8".....9
114.....	TSCE10-114.....	Arbor Bracket.....1
.....	TSCE12-114.....	Arbor Bracket.....1
115.....	UOTS10-115.....	Spanner Nut.....1
.....	UOTS12-115.....	Spanner Nut.....1
116.....	UOTS10-116.....	Arbor Nut.....	5/8".....1
.....	UOTS12-116.....	Arbor Nut.....	3/4".....1
117.....	UOTS10-117.....	Spring Pin.....	M6x50.....1
118.....	UOTS10-118.....	Key.....	1/4"x1/4"x2-5/16"1
119.....	UOTS10-119.....	Flat Washer.....	7/16".....2
120.....	UOTS10-120.....	Hex Cap Screw.....	7/16"x1".....2

Motor and Trunnion Assembly

Index No.	Part No.	Description	Size	Qty.
121.....	TSCE10-121.....	Shaft.....	1
122.....	UOTS10L-122.....	Motor Bracket.....	1
123.....	UOTS10-123.....	Pin.....	1
124.....	UOTS10-124.....	Spring Clip.....	2
125.....	TSCE10-125.....	Poly V-Belt.....	PJ260.....1
.....	TSCE12-125.....	Poly V-Belt.....	PJ250.....1
126.....	TSCE10-126.....	Motor Plate.....	1
127.....	TSCE10-127.....	Motor Pulley.....	1
128.....	UOTS10-128.....	Flat Washer.....	5/16".....8
129.....	UOTS10-129.....	Lock Washer.....	5/16".....	...10
130.....	UOTS10-130.....	Hex Cap Screw.....	5/16"x3/4"...4
131.....	UOTS10-131.....	Motor.....	1
.....	UOTS12-131.....	Motor.....	1
132.....	UOTS10-132.....	Hex Socket Cap Screw.....	3/8"x1-1/2"...7
133.....	TSCE10-133.....	Rear Trunnion Bracket.....	1
134.....	UOTS10-134.....	Hex Nut.....	3/8".....5
135.....	UOTS10-135.....	Hex Socket Cap Screw.....	3/8"x1".....4
136.....	UOTS10-136.....	Spring Pin.....	M8x25.....4
137.....	UOTS10-137.....	Hex Nut.....	3/4".....1
138.....	UOTS10-138.....	Fiber Washer.....	3/4".....4
139.....	TSCE10-139.....	Rear Trunnion.....	1
140.....	UOTS10-140.....	Bushing.....	1
141.....	TSCE10-141.....	Yoke.....	1
.....	TSCE12-141.....	Yoke.....	1
142.....	UOTS10-142.....	Set Screw.....	5/16"x1/4"....2
143.....	UOTS10-143.....	Collar.....	2
144.....	TSCE10-144.....	Shaft.....	1
.....	TSCE12-144.....	Shaft.....	1
145.....	UOTS10-145.....	Spring Pin.....	M5x30.....2
146.....	UOTS10-146.....	Worm Gear.....	2
147.....	UOTS10-147.....	Lock Pin.....	4
148.....	UOTS10-148.....	Key.....	M5x35.....2
149.....	TSCE10-149.....	Hex Socket Cap Screw.....	5/16"x1/2"....2

Motor and Trunnion Assembly

Index No.	Part No.	Description	Size	Qty.
150.....	TSCE10-150.....	Dust Deflector.....1
.....	TSCE12-150.....	Dust Deflector.....1
151.....	TSCE10-151.....	Hose Clamp.....	M100.....2
152.....	TSCE10-152.....	Front Trunnion.....1
153.....	UOTS10-153.....	Hex Cap Bolt.....	5/16"x5/8"...2
154.....	UOTS10-154.....	Hex Nut.....	5/16".....2
155.....	UOTS10-155.....	Lock Handle.....2
156.....	UOTS10-156.....	Fiber Washer.....	3/4".....2
157.....	UOTS10-157.....	Hex Socket Cap Screw.....	5/16"x1".....4
.....	TSCE12-157.....	Hex Socket Cap Screw.....	5/16"x2".....2
158.....	TSCE10-158.....	Front Trunnion Bracket.....1
159.....	UOTS10-159.....	Hand Wheel Handle.....2
160.....	UOTS10-160.....	Hand Wheel.....2
161.....	UOTS10-161.....	Shield Plate.....1
162.....	UOTS10-162.....	Round Head Screw.....	1/4"x3/8".....1
163.....	UOTS10-163.....	Pointer.....1
164.....	UOTS10-164.....	Pointer Bracket.....1
165.....	UOTS10-165.....	Round Head Screw.....	3/16"x2".....2
166.....	TSCE10-166.....	Guide Block.....1
167.....	UOTS10-167.....	Flat Washer.....	3/8".....1
168.....	UOTS10-168.....	Bushing.....1
169.....	UOTS10-169.....	Tilt Shaft.....1
.....	TSCE12-169.....	Tilt Shaft.....1
170.....	UOTS10-170.....	Wrench.....1
.....	UOTS12-170.....	Wrench.....1
171.....	TSCE10-171.....	Hose.....1
172.....	TSCE10-172.....	Plate.....1
173.....	TSCE10-173.....	Hex Socket Cap Screw.....	5/16"x3/4"...3
174.....	TSCE10-174.....	Chip Plate.....1
.....	TSCE12-174.....	Chip Plate.....1
175.....	TSCE10-175.....	Flat Washer.....	3/16".....3
176.....	TSCE10-176.....	Lock Washer.....	3/16".....3
177.....	TSCE10-177.....	Hex Cap Bolt.....	3/16"x3/8"...3

Motor and Trunnion Assembly

Index No.	Part No.	Description	Size	Qty.
178.....	TSCE10-178.....	Special Screw.....1
179.....	TSCE10-179.....	Lock Pin.....1
180.....	TSCE10-180.....	Spring.....1
181.....	TSCE10-181.....	Nylon Nut.....	1/4".....3
182.....	TSCE10-182.....	Spring.....2
183.....	TSCE10-183.....	Guide Bracket.....1
.....	TSCE12-183.....	Guide Bracket.....1
184.....	TSCE10-184.....	Flat Head Screw.....	1/4"x1".....2
185.....	TSCE10-185.....	Special Screw.....1
186.....	TSCE10-186.....	Pilot Link Plate.....1
187.....	TSCE10-187.....	Nylon Nut.....	M6.....1
188.....	TSCE10-188.....	Plate.....1
189.....	TSCE10-189.....	Riving Knife Carrier Plate..1
.....	TSCE12-189.....	Riving Knife Carrier Plate..1
190.....	TSCE10-190.....	Flat Head Socket Screw.....	M5x12.....2
191.....	TSCE10-191.....	Riving Knife Carrier.....1
192.....	TSCE10-192.....	Spring.....1
193.....	TSCE10-193.....	Pressure Plate.....1
194.....	TSCE10-194.....	Flat Head Socket Screw.....	M6x20.....2
195.....	TSCE10-195.....	Crank Handle.....1
196.....	TSCE10-196.....	Nylon Nut.....	M8.....1
197.....	TSCE10-197.....	Spring Shim Ring.....1
.....	TSCE12-197.....	Spring Shim Ring.....1
198.....	TSCE10-198.....	Snap Ring.....	S52.....1
.....	TSCE12-198.....	Snap Ring.....	S58.....1
199.....	TSCE10-199.....	Set Screw.....	M6x10.....4
.....	TSCE12-199.....	Set Screw.....	M6x8.....4
200.....	TSCE10-200.....	Guide Block.....1

Blade Guard Assembly

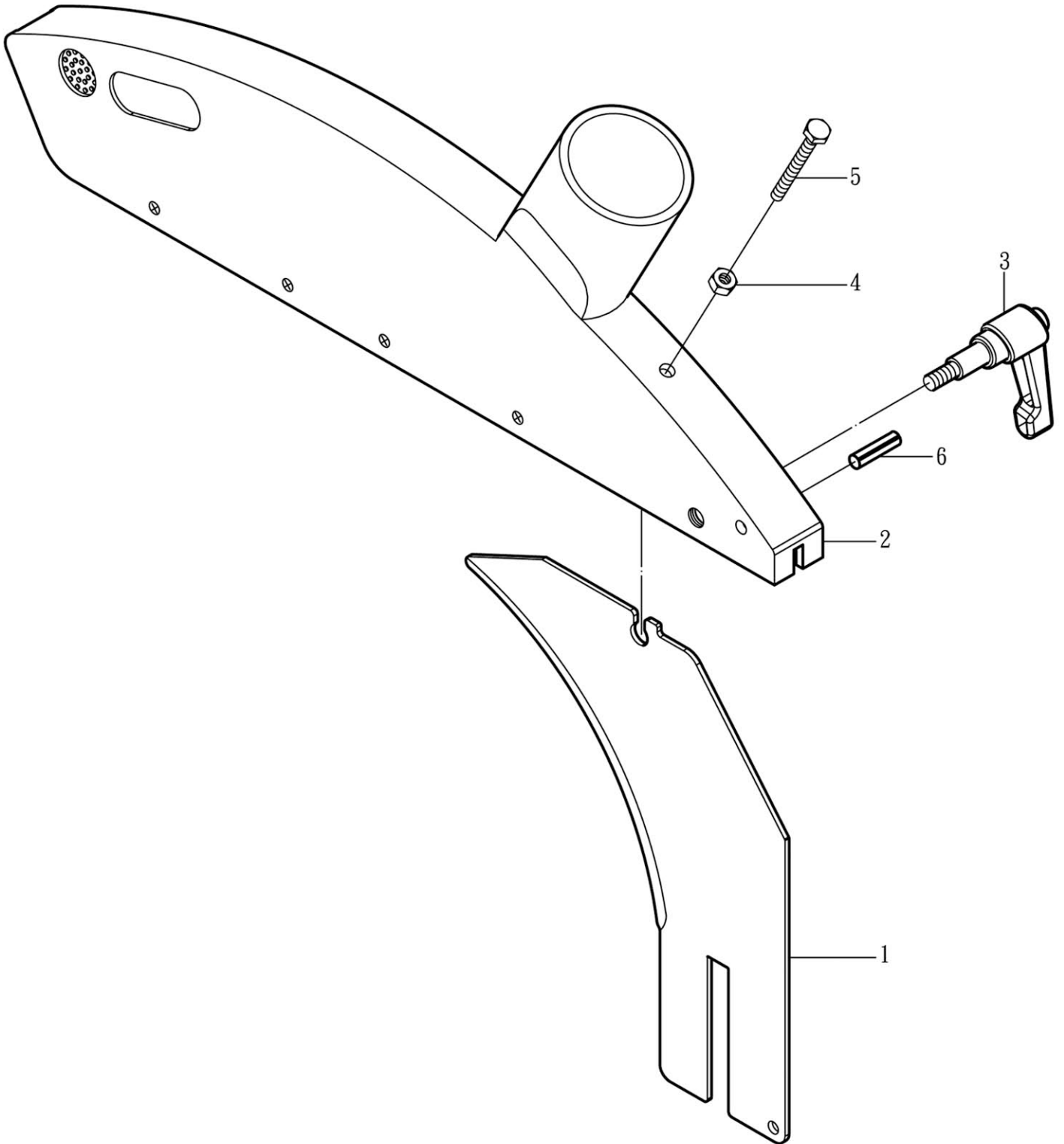

Blade Guard Assembly

Index No.	Part No.	Description	Size	Qty.
1.....	12200405.....	Riving Knife.....	1
2.....	12200401B.....	Guard.....	1
3.....	12200402.....	Crank Handle.....	1
4.....	910M08000.....	Hex Nut.....	M8.....1
5.....	904M08070.....	Hex Head Screw.....	M8x70.....1

Rip Fence Assembly

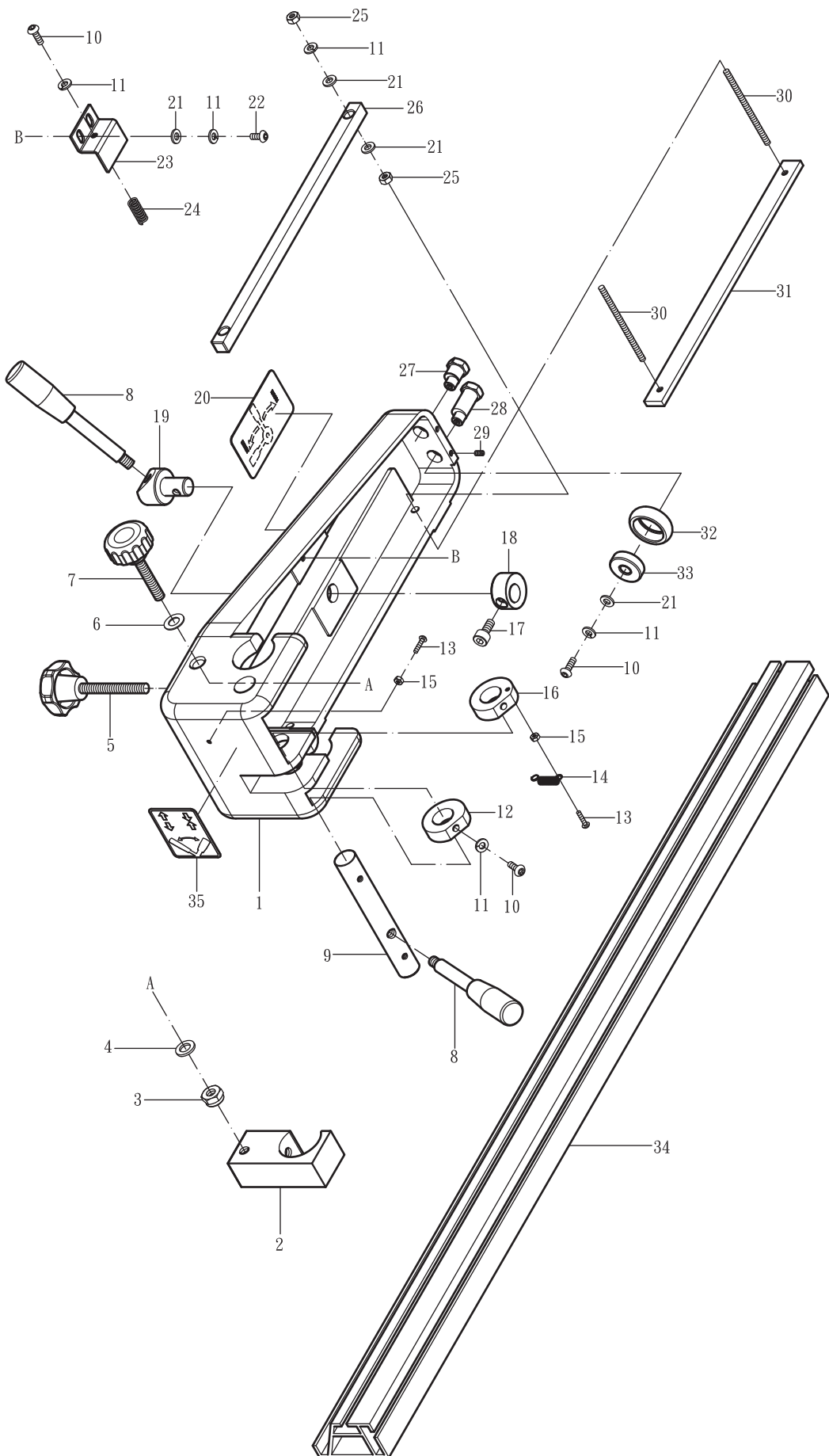

Rip Fence Assembly

Index No.	Part No.	Description	Size	Qty.
1.....	CE12F-1.....	Rip Fence Body.....	1
2.....	CE12F-2.....	Clamping Block.....	1
3.....	CE12F-3.....	Nylon Nut.....	M10.....1
4.....	CE12F-4.....	Flat Washer.....	M10.....1
5.....	CE12F-5.....	Knob.....	1
6.....	CE12F-6.....	Fiber Washer.....	M10.....1
7.....	CE12F-7.....	Knob.....	1
8.....	CE12F-8.....	Handle.....	2
9.....	CE12F-9.....	Eccentric Arbor.....	1
10.....	CE12F-10.....	Round Head Screw.....	M6x16.....5
11.....	CE12F-11.....	Lock Washer.....	M6.....9
12.....	CE12F-12.....	Eccentric Wheel (Lefe)...	1
13.....	CE12F-13.....	Round Head Screw.....	M4x16.....2
14.....	CE12F-14.....	Spring.....	1
15.....	CE12F-15.....	Hex Nut.....	M4x7.....2
16.....	CE12F-16.....	Eccentric Wheel (Right)..	1
17.....	CE12F-17.....	Hex Socket Cap Screw....	M8x16.....1
18.....	CE12F-18.....	Eccentric Wheel.....	1
19.....	CE12F-19.....	Handle Bar.....	1
20.....	CE12F-20.....	Sticker.....	1
21.....	CE12F-21.....	Flat Washer.....	M6.....8
22.....	CE12F-22.....	Round Head Screw.....	M6x12.....2
23.....	CE12F-23.....	Push Board.....	1
24.....	CE12F-24.....	Spring.....	1
25.....	CE12F-25.....	Hex Nut.....	M6.....4
26.....	CE12F-26.....	Lock Block.....	1
27.....	CE12F-27.....	Eccentric Nut (Short).....	1
28.....	CE12F-28.....	Eccentric Nut (Long).....	1
29.....	CE12F-29.....	Set Screw.....	M5x8.....2
30.....	CE12F-30.....	Screw.....	2
31.....	CE12F-31.....	Lock Bar.....	1
32.....	CE12F-32.....	Plastic Wheel.....	2

Rip Fence Assembly

Index No.	Part No.	Description	Size	Qty.
33.....	CE12F-33.....	Ball Bearing.....	6200zz.....2
34.....	CE12F-34.....	Stop Profile.....1
35.....	CE12F-35.....	Sticker.....1

Sliding Table System Assembly (UST-36)

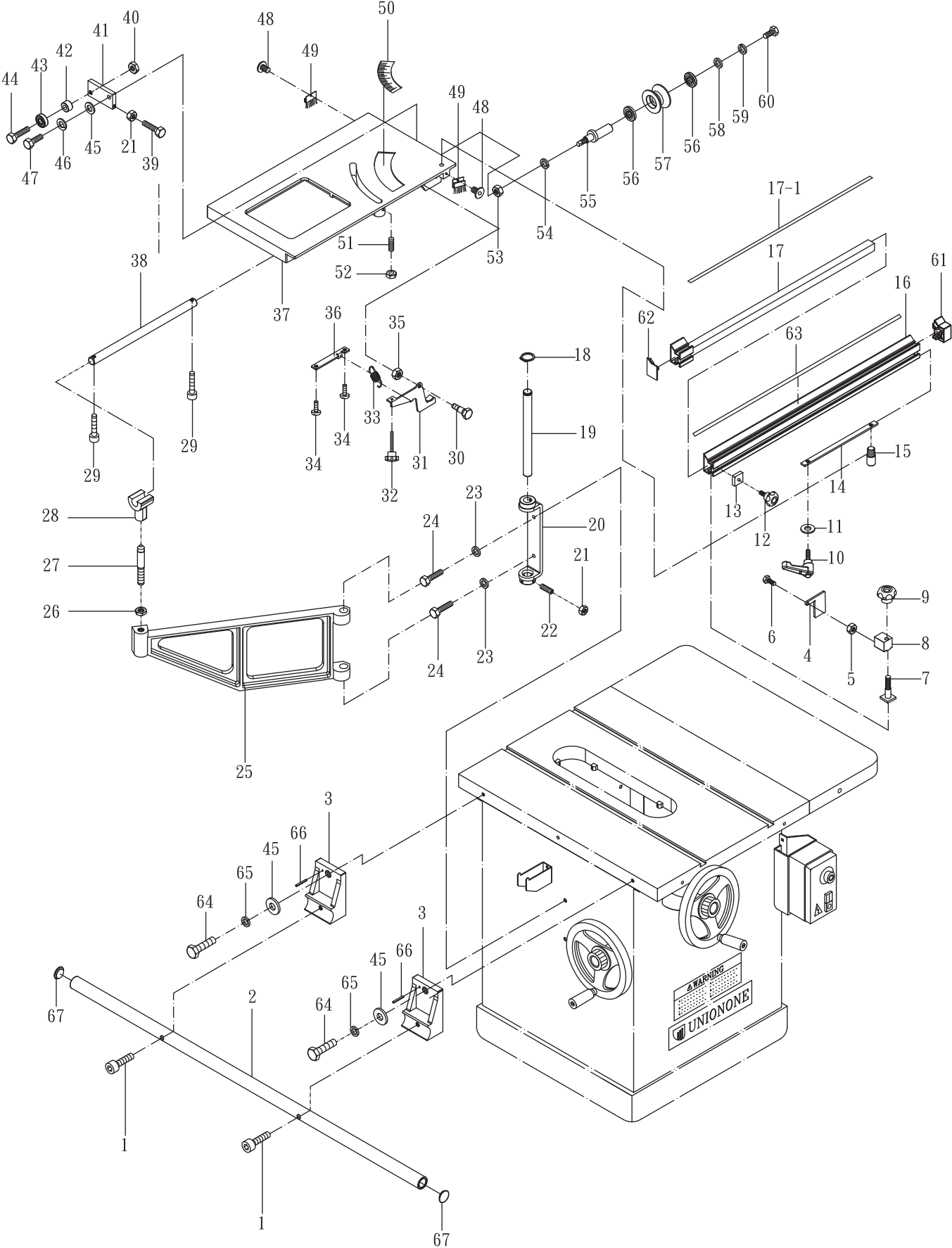

Sliding Table Assembly (Optional)

Index No.	Part No.	Description	Size	Qty.
1.....	231-4101.....	Hex Socket Cap Screw...	3/8"x1".....2
2.....	231-4102.....	Guide Shaft.....	1
3.....	231-4103.....	Guide Rail Bracket.....	2
4.....	231-4104.....	Plate.....	1
5.....	231-4105.....	Hex Nut.....	M8.....1
6.....	231-4106.....	Hex Socket Cap Screw....	M8x20.....1
7.....	231-4107.....	Special Bolt.....	1
8.....	231-4108.....	Flip Stop Base.....	1
9.....	231-4109.....	Knob.....	1
10.....	231-41010.....	Lock Handle.....	1
11.....	231-41011.....	Flat Washer.....	M12.....1
12.....	231-41012.....	Knob.....	1
13.....	231-41013.....	Square Nut.....	M8.....1
14.....	231-41014.....	Guide Bar.....	1
15.....	231-41015.....	Stud.....	1
16.....	231-41016.....	Profile Cross Cut Fence...	1
17.....	231-41017.....	Profile 2.Throw-over Stop	1
18.....	231-41018.....	Snap Ring.....	M24.....1
19.....	231-41019.....	Swing Arm Shaft.....	1
20.....	231-41020.....	Swing Arm Bracket.....	1
21.....	231-41021.....	Hex Nut.....	M8.....6
22.....	231-41022.....	Set Screw.....	M8x20.....5
23.....	231-41023.....	Lock Washer.....	M10.....2
24.....	231-41024.....	Hex Head Bolt.....	M10x40.....2
25.....	231-41025.....	Swing Arm.....	1
26.....	231-41026.....	Hex Nut.....	M20.....1
27.....	231-41027.....	Support Rod.....	1
28.....	231-41028.....	Rod Housing.....	1
29.....	231-41029.....	Hex Socket Cap Screw...	M8x35.....2
30.....	231-41030.....	Special Bolt.....	1
31.....	231-41031.....	Lock Bracket.....	1
32.....	231-41032.....	Knob.....	1
33.....	231-41033.....	Spring.....	1

Sliding Table Assembly (Optional)

Index No.	Part No.	Description	Size	Qty.
34.....	231-41034.....	Round Head Screw.....	M4x10.....2
35.....	231-41035.....	Nylon Nut.....	5/16".....1
36.....	231-41036.....	Plate1
37.....	231-41037.....	Work Table.....	1
38.....	231-41038.....	Cross Shaft.....	1
39.....	231-41039.....	Hex Head Bolt.....	M8x30.....1
40.....	231-41040.....	Hex Nut.....	M12.....1
41.....	231-41041.....	Roller Adjuster.....	1
42.....	231-41042.....	Spacer.....	1
43.....	231-41043.....	Ball Bearing.....	6201zz.....1
44.....	231-41044.....	Hex Head Bolt.....	M12x45.....1
45.....	231-41045.....	Flat Washer.....	M12.....1
46.....	231-41046.....	Lock Washer.....	M12.....1
47.....	231-41047.....	Hex Socket Cap Bolt.....	M12x35.....1
48.....	231-41048.....	Round Head Socket Screw...	M6x10.....2
49.....	231-41049.....	Brush.....	2
50.....	231-41050.....	Tilt Scale.....	1
51.....	231-41051.....	Set Screw.....	M8x20.....1
52.....	231-41052.....	Hex Nut.....	M8.....1
53.....	231-41053.....	Hex Nut.....	3/8".....2
54.....	231-41054.....	Lock Washer.....	M10.....2
55.....	231-41055.....	Shaft.....	2
56.....	231-41056.....	Ball Bearing.....	6202zz.....4
57.....	231-41057.....	Roller Housing.....	2
58.....	231-41058.....	Lock Washer.....	M8.....2
59.....	231-41059.....	Lock Washer.....	5/16".....2
60.....	231-41060.....	Hex Head Bolt.....	5/16"x5/8"....2
61.....	231-41061.....	Cap Cover Right.....	1
62.....	231-41062.....	Cap Cover Left.....	1
63.....	231-41063.....	Measuring Rule 0-940mm...	1
64.....	231-41064.....	Hex Cap Bolt.....	7/16"x1-1/2"2
65.....	231-41065.....	Lock Washer.....	7/16".....2
66.....	231-41066.....	Flat Washer.....	7/16".....2
67.....	231-41067.....	Lock Pin.....	M5x23.....2

The **Axminster guarantee** is available on Hobby, Trade, Industrial, Engineer, Air Tools & Axcnc Technology Series machines

It's probably the most comprehensive FREE guarantee ever- buy with confidence from Axminster!
So sure are we of the quality, we cover all parts and labour free of charge for three years!

- **Look for the icon and put your trust in Axminster**
- **No registration necessary - just keep your proof of purchase**
- **Optional Service Plan for Industrial Series machinery**



Great value & easy-to-use,
perfect for use at home



Solid, reliable machines
designed for daily use



Top performers with class leading features and
build quality for use in busy workshops



Quality, precision machines
for the workshop or education



Small machines for the home
engineer



Compressors and tools for home or
workshop use, durable and great value



Precision CNC machines for
industry and education

Free Three Year Guarantee on Axminster Hobby, Trade and Industrial Series woodworking and engineering machines, Axminster Air compressors and Air Tools, and bench top grinders - no registration necessary just proof of purchase.

We will repair or replace at our discretion and will collect only from a UK mainland address, irrespective of the original delivery address

The Guarantee assumes that you have bought the correct machine for the required operation, in accordance with our guidelines; have operated and maintained it in accordance with the instruction manual; and that all cutting machines will be used with a blade which is sharp and serviceable at all times. It does not cover consumable items purchased with the original product, including original blades or abrasives

Normal wear and tear, misuse, abuse and neglect are excluded and the machine should not have been modified in any way. Please do not attempt to service the product without first contacting us; we are happy to guide you but failure to do so may invalidate the guarantee

The Guarantee is transferable from owner to owner in the first three years but you must have original proof of purchase. Should we need to replace a machine in the first three years the guarantee will still continue to be effective from the original purchase date

Full Terms and Conditions can be found here. This guarantee does not affect your statutory rights.

For more information visit axminster.co.uk/3years



Please dispose of packaging for the product in a responsible manner. It is suitable for recycling. Help to protect the environment, take the packaging to the local recycling centre and place into the appropriate recycling bin.

Only for EU countries



Do not dispose of electric tools together with household waste material. In observance of European Directive 2002/96/EC on waste electrical and electronic equipment and its implementation in accordance with national law, electric tools that have reached the end of their life must be collected separately and returned to an environmentally compatible recycling facility.

Axminster Tool Centre,
Unit 10 Weycroft Avenue, Axminster, Devon EX13 5PH

axminster.co.uk